

## PD410 Circular PICMA<sup>®</sup> Bender Piezo Actuators



Figure 1: Circular PICMA<sup>®</sup> bender actuator (here: PD410.10)

### INFORMATION

Before soldering, installing and operating the actuator, read these descriptions and instructions carefully!

## Safety

The following instructions will help you to obtain maximum performance from your actuator and avoid failures. Failure to heed warnings in this document may result in injuries (caution) or material damage (notice).

### CAUTION



#### Risk of electric shock!

These devices require adequately trained and experienced operating personnel.

Since temperature changes and compressive stresses can induce charges in piezo actuators, even unused actuators may be a source of electric shocks.

To avoid electric shock:

- Do **not** disassemble the piezoelectric actuator.
- Make sure the bare piezoelectric actuator is discharged **before** touching it and keep the soldering pads or wires **shorted** before installation.
- Use gloves and safety glasses during handling.

## NOTICE



### Risk of damage from inadequate handling!

Inadequate shorting or handling may damage the actuator.

- When shorting the wires or soldering pads of a possibly charged actuator, always use a 10 kΩ current limiting resistor. Shorting a charged actuator without limiting the discharge current can fracture the PZT ceramics due to the extremely high dynamic forces caused by the rapid discharge.
- Do **not** operate the actuator at higher voltages or different polarity than stated in this document. For polarity information, see below.
- Power off the actuator immediately if you hear or see any resonant behavior. For the unloaded resonant frequency see *Technical Data*. Any resonant operation should generally be avoided. Due to self-heating effects, the specified operating temperature range of the actuator could be exceeded rapidly and irreparable damage may occur.
- Do **not** exceed the operating temperatures stated in the *Technical Data* section.
- Before operating, check whether the instructions on soldering (if applicable), installation and handling have been obeyed.
- If you use a conductive support for fixing the actuator, electrically insulate the corresponding parts of the soldering contacts.
- Do **not** drop the piezo actuator; avoid subjecting it to any kind of mechanical shock.
- Do **not** exceed the maximum load (blocking force) specified in the *Technical Data*.

## NOTICE



### Risk of damage from inadequate environmental conditions!

The actuator is sensitive to moisture, high relative humidity, liquids and contact with any other conductive material.

- Avoid storing or operating actuators under these environmental conditions since they can cause dielectric breakdown.
- Ensure that moisture is as low as possible.

## NOTICE



### Risk of damage from contamination!

To avoid contamination:

- Do **not** handle the actuator with unprotected fingers.
- Always use latex or nitrile gloves. The gloves **must not** be powdered.
- Use parallel-action non-metallic tweezers to handle the actuator.
- Use isopropanol to remove contaminants.

## NOTICE



### Risk of damage from thermal and mechanical stress!

- Be sure that the solder joint is **not** subject to “peeling” forces.
- On the actuator surface, do **not** exceed 150 °C (302 °F). Except for soldering (see below), this limitation applies to all processing steps as well as to operation. Consider that the operation of the actuator can cause heating-up.
- Do **not** file, sand or roughen the sides of the actuator.

## Features

### INFORMATION

Custom designs or different specifications on request.  
Feel free to contact PI Ceramic GmbH!

### Actuators with high reliability

Low temperature drift. Bidirectional displacements. Ceramic insulation, polymer-free. UHV-compatible to  $10^{-9}$  hPa, no outgassing, high bakeout temperature. Reliable even under extreme conditions.

### Fields of application

Research and industry, valves, pumps, dosing systems, vacuum applications. For medical technology, autofocussing, laser control, automation tasks.

### Suitable drivers

E-650 piezo amplifier for multilayer bender actuators, available from PI.

## Product Details

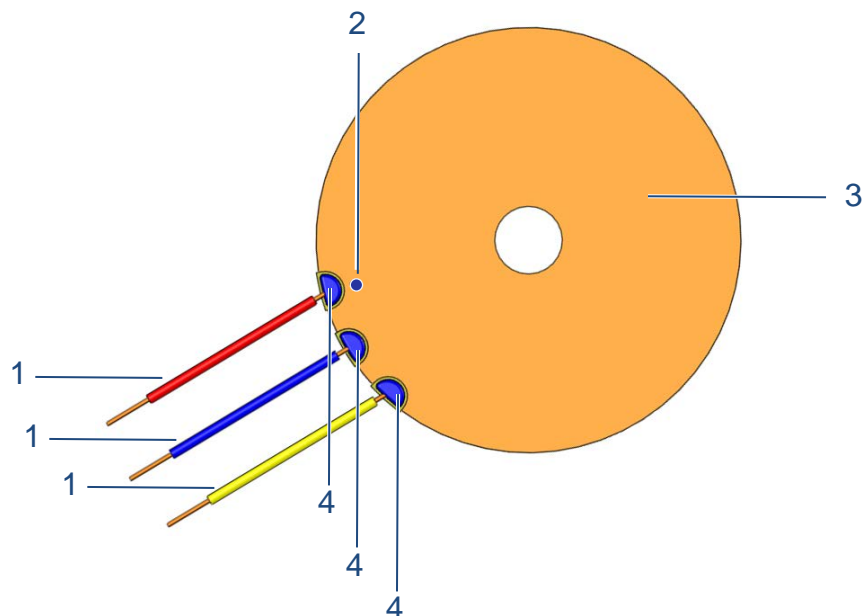

Figure 2: Details of the actuator, top view (schematic) with

- 1 wire (only for PD410.11)
- 2 plus or dot mark indicating positive ( $U_+$ ) contact position
- 3 actuator body
- 4 soldering pad

## Design and Functional Principle

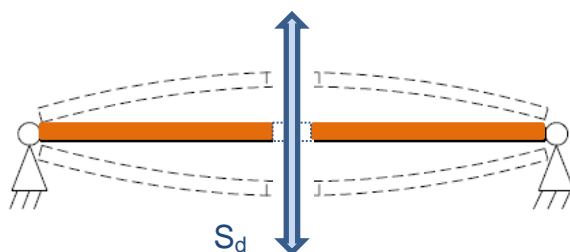

Figure 3: Displacement  $S_d$  caused by contractions (schematic; bidirectional for full-differential control)

The actuator, shown in Figure 3, is built up from thin piezoceramic layers and internal electrodes. The internal electrodes extend across the entire cross section of the actuator and are connected to three external electrodes (called "soldering pads" in the following text). The thickness of the piezo layers expands and the length contracts if a voltage of the correct polarity is applied to the soldering pads. The bending movement (hence displacement) is caused by the contraction (" $d_{31}$ -effect").

## Installation

### Mounting Wires / Soldering

We recommend ordering the actuator with already mounted wires (PD410.11). For PD410.10, follow the instructions below.

The following extra materials are required for the soldering process:

- **Solder:** lead-free, made of the system **L-Sn95..97 Ag3..4 Cu0.5..1.0**
- **Flux:** defined as **1.1.1** or **1.1.3** accordingly to DIN EN 29454 Part 1 or defined as **ROLO** or **ROMO** according to ANSI J-STD-004
- **Wires:** 3 stranded wires, ideal: AWG 32 (max. AWG 30), cut and stripped according to your demands

### Soldering wires to a PD410.10 actuator

#### INFORMATION

The following procedure applies for each of the three wires and soldering pads intended for connection to the piezo amplifier.

1. Twist and tin one stripped end of the wire. Trim to 2 mm.

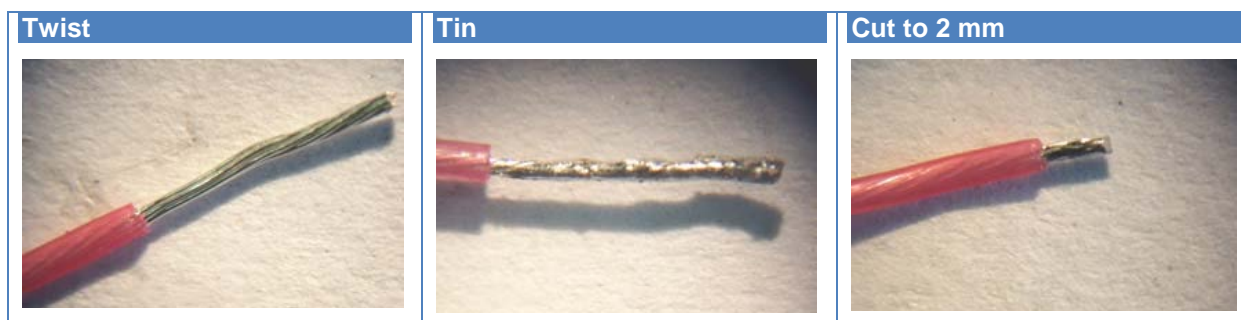

Figure 4: Wire preparation steps (schematic)

2. Apply flux to the tinned end and to the soldering pad. Hold the wire flat with its end at that point.
3. Coat the soldering tip with a small amount of solder. The soldering temperature **must not** exceed 350 °C (662 °F).
4. On the soldering pad (flat top), hold the soldering tip against the tinned end of the wire for 1 to max. 2 seconds, until the solder flows. The solder joint must be flat or hemispherical.

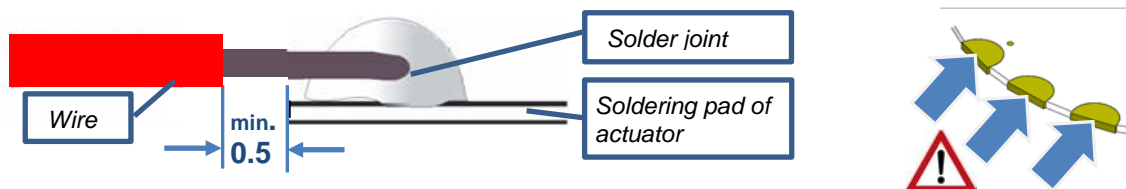

Figure 5: Left: Solder joint shape (sectional view); right: **sensitive edges; do not solder here!**

During long and consecutive soldering, the soldering pad can be dissolved in the melt solder. Overall soldering time has to be limited to 4 seconds.

Do **not** solder on the edge of the soldering pad (where the soldering contact is bent). Minimum distance of the wire insulation to the edge of the soldering contact should be 0.5 mm.

5. Remove flux residues in a cleaning process by applying ethanol or a higher alcohol type. Use of an ultrasonic bath is recommended.

## Mechanical Installation

To ensure low curing temperature (for minimized material stress when cooling), we recommend using a two-component epoxy adhesive for mounting both the actuator and the mechanical output.

### Installation of a mechanical output

The aperture of the actuator allows mounting a mechanical output (see *Figure 6* and *Figure 7*). The output and its fixation have to be adapted to the actuator regarding the following items:

- dimensions
- weight and resulting forces / torques
- temperature coefficient of the material (if the assembly is operated in wide temperature ranges)

We recommend installing the output before installing the actuator in a mount.

### Installation of the actuator in a mount

#### NOTICE



#### Risk of breaking the actuator with inadequate mounting

The actuator contracts and expands laterally during operation. Consequently, a very stiff fixation may corrupt the performance or damage the actuator.

- Ensure radial flexibility.

#### NOTICE



#### Risk of shortage at the contacts

- If non-insulating fixture material is used, ensure that the contact region is recessed

The ideal fixation at the outer diameter is axially stiff, radially flexible. Two applicable configurations are shown below.

#### Option A

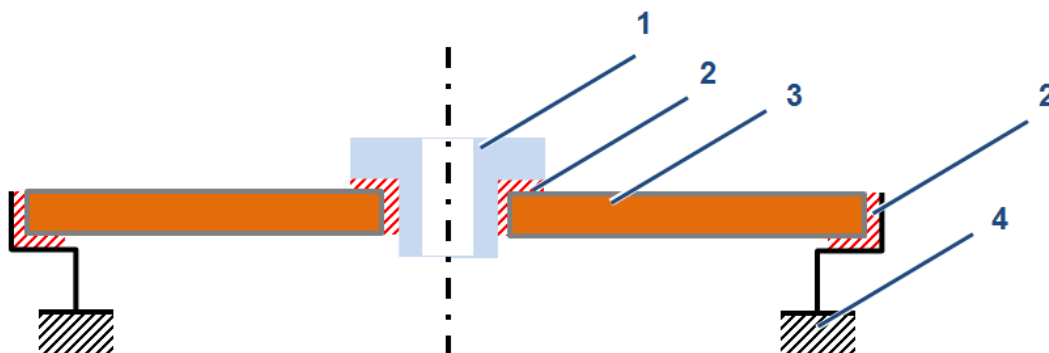

Figure 6. Ideal mechanical fixation (sectional view; axially symmetric) with

1. mechanical output
2. epoxy adhesive
3. actuator
4. mount

In the figure above, the actuator is glued to a flexible metal structure (mount) using epoxy adhesive. This mechanical connection should have minimal rotational stiffness (no complete ring). It should provide minimal distance between actuator and mount in order to minimize torques. For force loads below 2 N, it is possible to fix the bender at 3 single points each with 120° axial offset.

### Option B

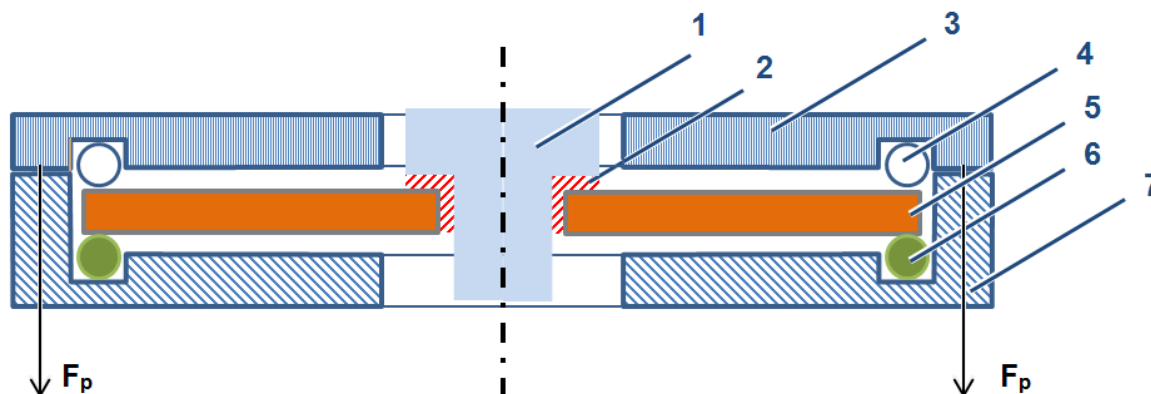

Figure 7. Ideal mechanical fixation, option B (sectional view; axially symmetric) with

- 1 mechanical output
- 2 epoxy adhesive
- 3 mount, part 1 (upper turned part)
- 4 soft ring
- 5 actuator
- 6 helical spring
- 7 mount, part 2 (lower turned part)
- $F_p$  pressing force

In the figure above, the actuator is pressed on a stiff ring by a soft ring. The stiff ring may be a helical spring with small diameter, allowing tangential contraction. Ideally, the soft ring is made of FKM (e.g. Viton<sup>®</sup>, as used for vacuum sealings). The rings can be mounted by two low-profile metal ring notches (turned parts) with a maximal pressing force of 20 N which is equally distributed.

## Electric Connection

### INFORMATION

We recommend using the E-650 piezo amplifier available from PI.

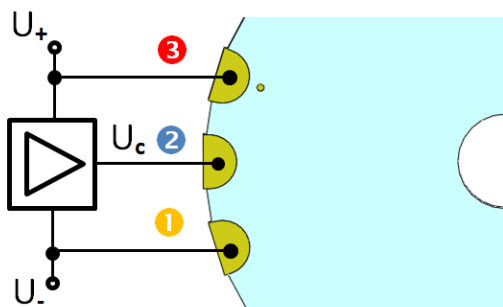

Figure 8: Electric connection scheme with  
(1) – (3) Soldering pads No. 1, 2, 3 (and for PD410.11: related wires)

See *Figure 8*: In relation to the dot or “plus” mark, the nearest soldering pad No. 3 (or red wire respectively, if a PD410.11 model is used) must be connected to  $U_+$  and the most distant soldering pad No. 1 (or yellow wire for PD410.11) has to be attached to  $U_-$  respectively. Soldering pad No. 2 (or blue wire for PD410.11) is intended for connection to the control voltage  $U_c$  generated by the piezo amplifier.

## Operation

### NOTICE



#### Risk of damage from improper polarity and voltage!

- Do **not** reverse polarity.
- Between soldering pads / wires No. 3 and 1 and for  $U_c$ : Do **not** exceed 60 V.  
See *Figure 8*.

## Controlling the Displacement via Applied Voltages

### Single voltage control

If a voltage is applied between two soldering pads, the actuator bends in one direction only. E.g. for 60 V, a displacement of max. 240  $\mu\text{m}$  is reached at the mechanical output in the center of the actuator. The active piezo layers contract in length, and the other layers become passive (no shape change).

### Full differential-voltage control (recommended)

Based on the **full differential-voltage control** (see *Figure 8*), bending can be controlled over the full range in both directions. I.e. an overall displacement of 480  $\mu\text{m}$  can be reached.

### Operating options

Regarding the voltages, the options shown in the table below apply.

Soldering contact / wire no. (according to <i>Figure 8</i> )	1	2	3
Voltage designation	$U_-$	$U_c$	$U_+$
Option 1	GND	0 V to 60 V	60 V
Option 2	-30 V	-30 V to 30 V	30 V

### Displacement direction

If the soldering pads of the bender point to the top and the bender is driven with a positive voltage at contact no. 3 and 2 and GND at contact no. 1, its center bends to the bottom.

## Storage

Store the components in a dry place (non-condensing) at room temperature.



## Dimensions

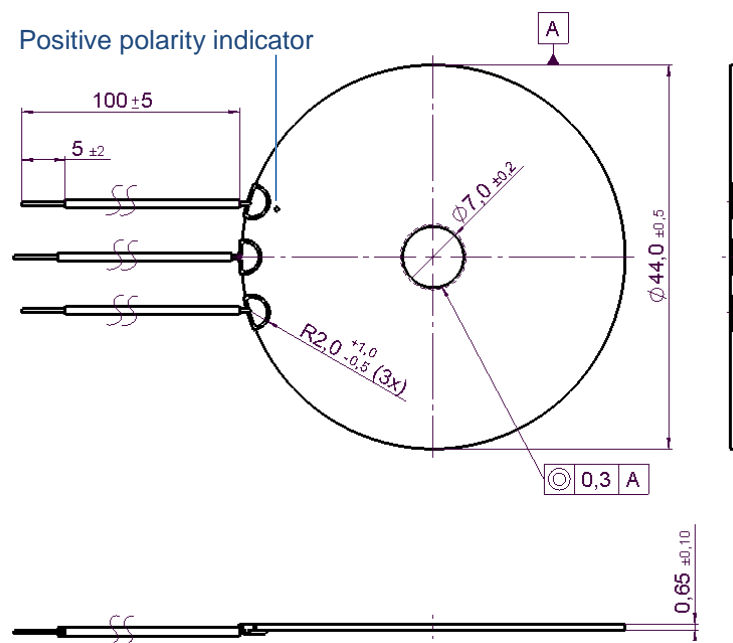

Figure 9: Actuator dimensions (here: **PD410.11**). Values in mm, decimal places separated by commas.

## Technical Data

	PD410.10 PD410.11*	Unit	Tolerance
Operating voltage**	0 to +60 or -30 to +30	V	
Displacement	-240 to +240	µm	±20%
Dimensions (outer diameter x inner diameter x thickness)	44 x 7 x 0.65	mm x mm x mm	see figure above
Blocking force	-16 to +16	N	±20%
Electrical capacitance***	2 * 10.5	µF	±20%
Resonant frequency****	1000	Hz	±20%
Operating temperature	-20 to +150	°C	
Piezoceramics type	PIC252		

\* with mounted 100 mm PTFE-insulated wires, AWG 32 (Ø 0.49 mm)

\*\* depending on electric connection option, see above

\*\*\* at  $U_{pp} = 1$  V (differential peak voltage), 1 kHz, 20 °C

\*\*\*\* at  $U_{pp} = 1$  V, without mass load

**Note:** Some specifications may vary depending on the actual clamping / mounting conditions and on the applied mechanical load.

**Custom designs and different specifications on request!**