

PIglide RL Low-Profile Rotation Stage with Air Bearing

Friction-Free, Motorized



A-63x

- 200 mm or 300 mm motion platform diameter
- Low profile, 60 mm
- Eccentricity and flatness < 100 nm
- Option for self-locking at rest by magnetic preload

Product Overview

The directly driven low-profile rotation stages of the PIglide RL series are designed for the highest precision with low-profile design.

Various options can be combined to create a solution ideal for point-to-point indexing or constant velocity scanning. The RL stages offer superior travel accuracy, flatness, and wobble performance.

3-phase torque motor

- Brushless
- Slotless
- Low cogging torque

Absolute encoder (optional)

Absolute encoders supply explicit position information that enables immediate determination of the position. This means that referencing is not required during switch-on, which increases efficiency and safety during operation.

Accessories and options

- Incremental or absolute encoder
- Vacuum feedthrough
- Self-locking at rest by magnetic preload
- PIglide filter and air preparation kit
- Single or multi-axis motion controllers and servo drives
- Multi-axis/customized designs
- Base plates made of granite and systems for reducing vibration

Application fields

Optical alignment, wafer inspection, wafer alignment, measuring technology, inspection systems, calibration, scanning. Thanks to the friction-free motion, no particles are formed, which makes PIglide stages ideal for cleanroom applications.

Specifications

Motion	A-635	A-637	Unit	Tolerance
Travel range	unlimited, > 360°	unlimited, > 360°		
Motion platform diameter	200	300	mm	
Eccentricity ⁽¹⁾	100	100	nm	max.
Flatness ⁽¹⁾	50	50	nm	max.
Wobble ⁽¹⁾	2	1	μrad	max.

Mechanical properties	A-635	A-637	Unit	Tolerance
Load capacity, axial ⁽²⁾	200	500	N	max.
Load capacity, radial ⁽²⁾	50	200	N	max.
Load torque, $M_{x,y}$ ⁽²⁾	5	10	N·m	max.
Moment of inertia	25,820	72,000	kg·mm ²	
Moved mass	4.2	6.4	kg	
Overall mass	7.5	14	kg	
Guide type	Air bearing, magnetic preload	Air bearing, magnetic preload		

Drive properties	A-63x	Unit	Tolerance
Drive type	Torque motor, 3-phase, brushless, ironless, slotless		
Intermediate circuit voltage, effective	48, nominal 80, max.	V DC	
Peak torque	9	N·m	typ.
Nominal torque	3	N·m	typ.
Torque constant, effective	0.66	N·m/A	typ.
Resistance phase-phase	4.5	Ω	
Inductance phase-phase	0.6	mH	
Back EMF phase-phase	80	V/kRPM	max.

Positioning	A-63x.A100	A-63x.B100
Integrated sensor	Incremental angle-measuring system	Absolute angle-measuring system
Sensor signal	Sin/cos, 1 V peak-peak	BiSS-C
Lines/revolution	A-635: 31,488 A-637: 47,200	–
Velocity ⁽³⁾	A-635: 500 rpm max. A-637: 500 rpm max.	A-635: 500 rpm max. A-637: 500 rpm max.
Sensor resolution	A-635: 0.05 μrad ⁽⁴⁾ A-637: 0.03 μrad ⁽⁴⁾	A-635: 0.0015 μrad A-637: 0.0015 μrad
Bidirectional repeatability	± 2 μrad	± 2 μrad
Accuracy, with error compensation ⁽⁵⁾	± 6 μrad	± 6 μrad
Reference point switch	1 / revolution, differential pulse over one sensor signal period, 1 V peak-peak	–

Miscellaneous	A-63x
Operating pressure ⁽⁶⁾	75 to 85 psi (515 to 585 kPa)
Air consumption	< 2 SCFM (56 SLPM)
Air quality	Clean (filtered to 1.0 µm or better) - ISO 8573-1 Class 1 Oil free - ISO 8573-1 Class 1 Dry (-15 °C dew point) - ISO 8573-1 Class 3
Materials	Hardcoat aluminum, stainless steel fasteners

⁽¹⁾ Dependent on the quality of the underlying surface, the payload, orientation, and forces that act on the stage from the outside. Please contact PI for application-specific parameters. The specified values are static (no rotary motion during measuring) and without load.

⁽²⁾ The loads listed assume a supply pressure of 550 kPa (80 psi). Please contact PI if other pressures are required.

⁽³⁾ May be limited by the payload, payload imbalance, controller or drive.

⁽⁴⁾ Assumes 4096x interpolation. Contact PI for the use of other factors.

⁽⁵⁾ The specified values are based on error compensation controlled by the controller. The stage must be ordered with an A-8xx series controller from PI to reach these values. Accuracy values assume short-term duration and do not consider the long-term effects of thermal drift on the stage.

⁽⁶⁾ To protect the stage against damage, it is recommended to connect an air pressure sensor to the Motion-Stop input of the controller.

Drawings and Images

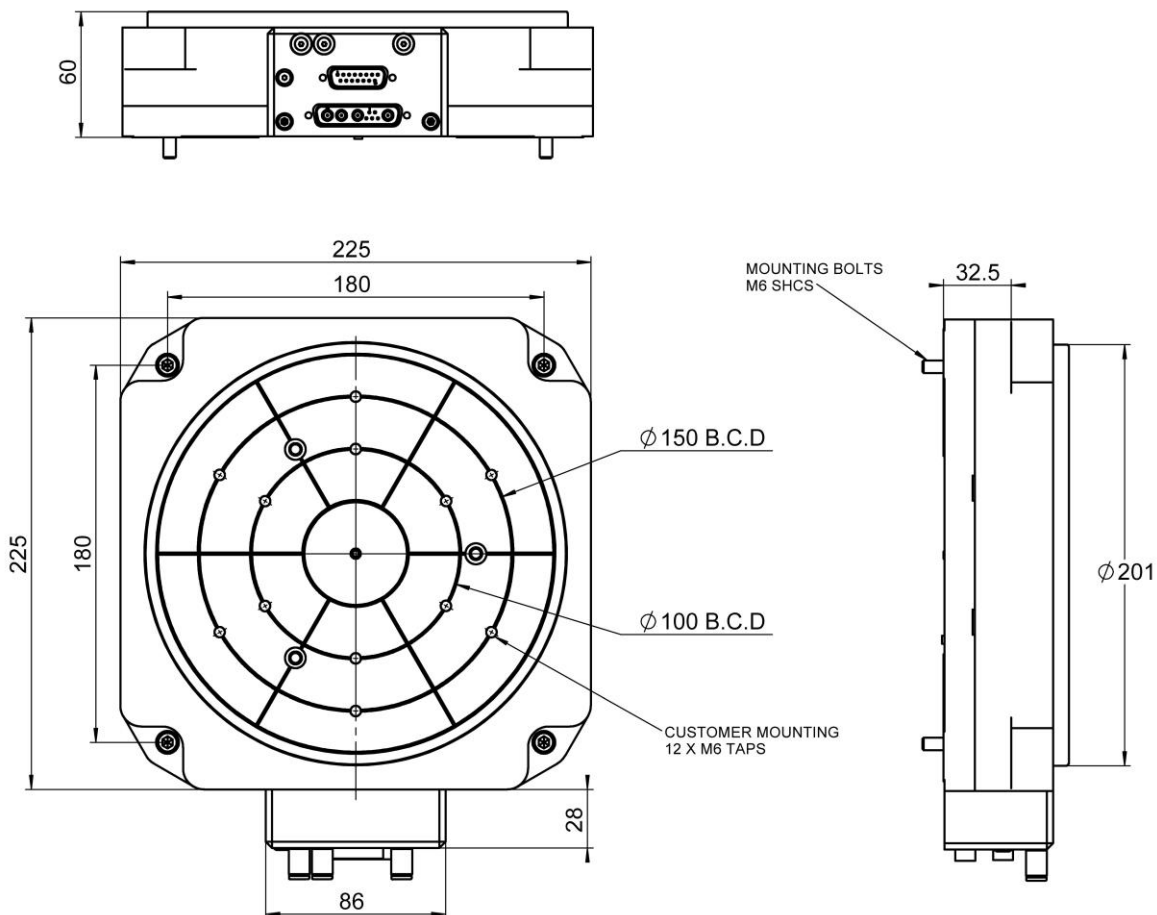

A-635.x100, dimensions in mm

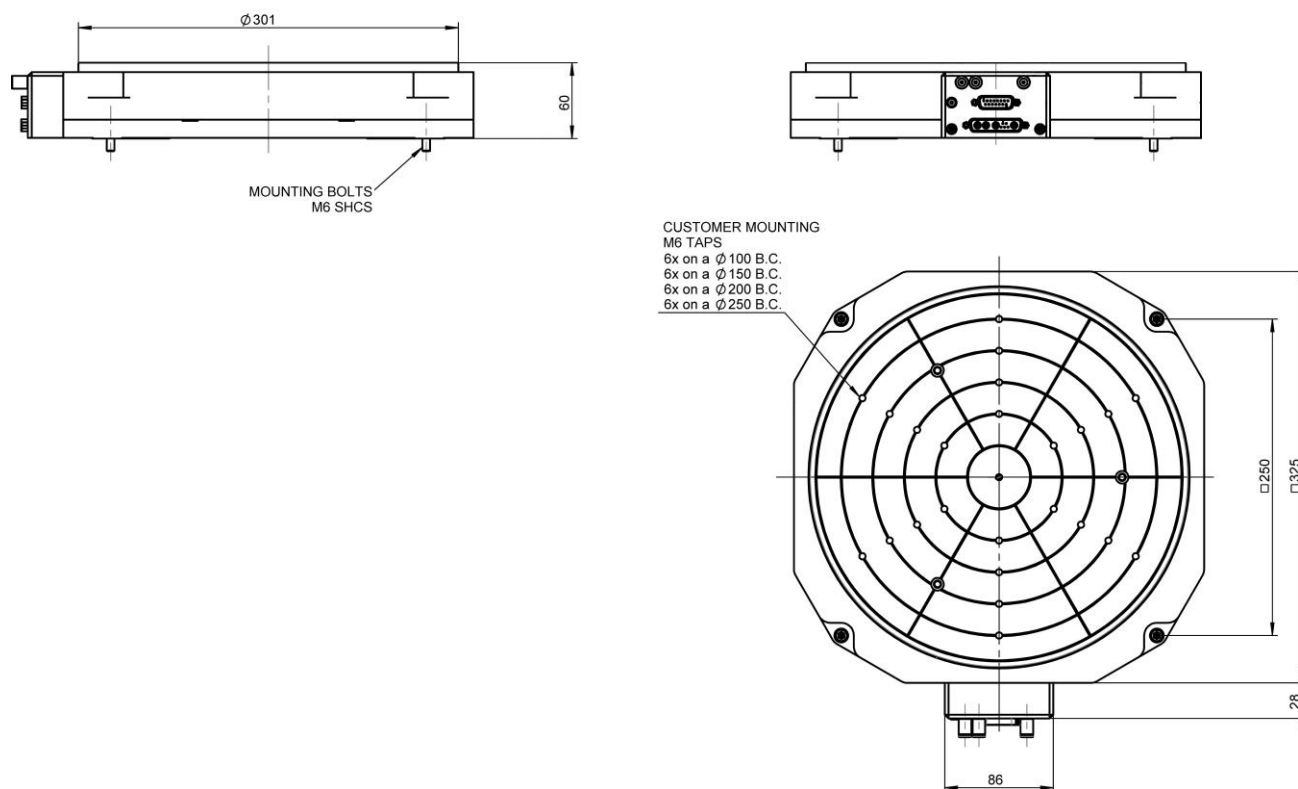

A-637.x100, dimensions in mm

Bestellinformationen

A-635.A100

PIglide RL rotation stage, air bearing, 200 mm motion platform diameter, low height, angle measuring system with sin/cos signal transmission, 31488 lines/revolution, slotless, brushless 3-phase torque motor

A-635.B100

PIglide RL rotation stage, air bearing, 200 mm motion platform diameter, low height, absolute angle-measuring system with BiSS-C signal transmission, 0.0015 μ rad sensor resolution, slotless, brushless 3-phase torque motor

A-637.A100

PIglide RL rotation stage, air bearing, 300 mm motion platform diameter, low height, angle measuring system with sin/cos signal transmission, 47200 lines/revolution, slotless, brushless 3-phase torque motor

A-637.B100

PIglide RL rotation stage, air bearing, 300 mm motion platform diameter, low height, absolute angle-measuring system with BiSS-C signal transmission, 0.0015 μ rad sensor resolution, slotless, brushless 3-phase torque motor