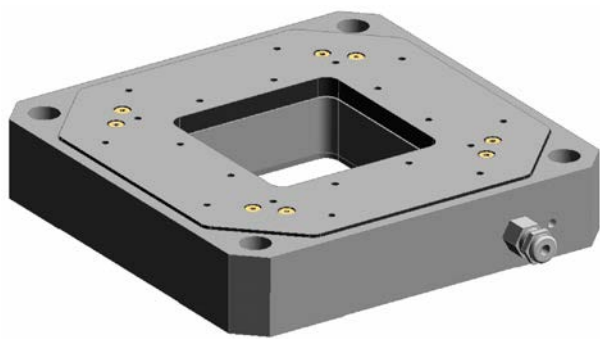


PZ82E P-5x7/P-5x8 Stage User Manual

Version: 3.0.0

Date: 05.09.2013



This document describes the following products:

- **P-517, P-527**
Precision XY Nanopositioning System
P-517.2CD/.2CL, 100 μm \times 100 μm
P-527.2CD/.2CL, 200 μm \times 200 μm
- **P-517, P-527**
Precision XYZ Nanopositioning System
P-517.3CD/.3CL, 100 μm \times 100 μm \times 20 μm
P-527.3CD/.3CL, 200 μm \times 200 μm \times 20 μm
- **P-517, P-527**
Precision XY / Rotation Nanopositioning System
P-517.RCD, 100 μm \times 100 μm , 2 mrad
P-527.RCD, 200 μm \times 200 μm , 4 mrad
- **P-558, P-518, P-528**
Precision Nanopositioning Z Stage
P-558.ZCD/.ZCL, 50 μm
P-518.ZCD/.ZCL, 100 μm
P-528.ZCD/.ZCL, 200 μm
- **P-558, P-518, P-528**
Precision Nanopositioning Z/Tip/Tilt Stage
P-558.TCD, 50 μm , 0.6 mrad
P-518.TCD, 100 μm , 1.4 mrad
P-528.TCD, 200 μm , 2.4 mrad

.2CD/.3CD/.ZCD/.RCD/.TCD with Sub-D connector

.2CL/.3CL/.ZCL with LEMO connector



Physik Instrumente (PI) GmbH & Co. KG is the owner of the following trademarks:
PI®, PIC®, PICMA®, PLine®, PIFOC®, PiezoWalk®, NEXACT®, NEXLINE®,
NanoCube®, NanoAutomation®, Picoactuator®, PInano®

The products described in this document are in part protected by the following patents:

German patent no. 10021919C2

German patent no. 10234787C1

German patent no. 10348836B3

German patent no. 102005015405B3

German patent no. 102007011652B4

US patent no. 7,449,077

Japanese patent no. 4667863

Chinese patent no. ZL03813218.4

© 2013 Physik Instrumente (PI) GmbH & Co. KG, Karlsruhe, Germany. The text, photographs and drawings in this manual are protected by copyright. With regard thereto, Physik Instrumente (PI) GmbH & Co. KG retains all the rights. Use of said text, photographs and drawings is permitted only in part and only upon citation of the source.

Original instructions

First printing: 05.09.2013

Document number: PZ82E, CBo, Version 3.0.0

Subject to change without notice. This manual is superseded by any new release. The latest release is available for download (p. 3) on our website.



Contents

1	About this Document	1
1.1	Goal and Target Audience of this User Manual	1
1.2	Symbols and Typographic Conventions	1
1.3	Other Applicable Documents	2
1.4	Downloading Manuals	3
2	Safety	5
2.1	Intended Use	5
2.2	General Safety Instructions	6
2.3	Organizational Measures	7
3	Product Description	9
3.1	Model Overview	9
3.2	Product View	11
3.3	Scope of Delivery	11
3.4	Recommended Piezo Controllers	12
3.5	Technical Features	13
3.5.1	PICMA® Piezo Actuators	13
3.5.2	Flexure Guides	13
3.5.3	Capacitive Sensors	14
3.5.4	ID Chip (Only Models With Sub-D Connector)	14
4	Unpacking	15
5	Installation	17
5.1	General Notes on Installation	17
5.2	Connecting the P-5x7/P-5x8 to the Protective Earth Conductor	19
5.3	Mounting the P-5x7/P-5x8	21
5.4	Affixing the Load	23
6	Start-Up and Operation	27
6.1	General Notes on Start-Up and Operation	27
6.2	Operating the P-5x7/P-5x8	29
6.3	Discharging the P-5x7/P-5x8	30

7	Maintenance	31
7.1	General Notes on Maintenance.....	31
7.2	Packing the P-5x7/P-5x8 for Transport	31
7.3	Cleaning the P-5x7/P-5x8.....	33
8	Troubleshooting	35
9	Customer Service	37
10	Technical Data	39
10.1	Specifications.....	39
10.1.1	Data Table	39
10.1.2	Maximum Ratings	42
10.2	Ambient Conditions and Classifications	43
10.3	Dimensions	44
10.4	Torque for Stainless Steel Screws (A2-70)	46
10.5	Pin Assignment.....	47
11	Old Equipment Disposal	51
12	EC Declaration of Conformity	53

1 About this Document

In this Chapter

Goal and Target Audience of this User Manual	1
Symbols and Typographic Conventions	1
Other Applicable Documents	2
Downloading Manuals	3

1.1 Goal and Target Audience of this User Manual

This user manual contains the necessary information for the intended use of the P-5x7/P-5x8 (x stands for the different models, p. 9).

Basic knowledge of control technology, drive technologies and suitable safety measures is assumed.

The latest versions of the user manuals are available for download (p. 3) on our website.

1.2 Symbols and Typographic Conventions

The following symbols and typographic conventions are used in this user manual:

CAUTION



Dangerous situation

If not avoided, the dangerous situation will result in minor injury.



- Actions to take to avoid the situation.

NOTICE




Dangerous situation

If not avoided, the dangerous situation will result in damage to the equipment.

- Actions to take to avoid the situation.

INFORMATION

Information for easier handling, tricks, tips, etc.

Symbol/ Label	Meaning
1.	Action consisting of several steps whose sequential order must be observed
2.	
➤	Action consisting of one or several steps whose sequential order is irrelevant
▪	List item
p. 5	Cross-reference to page 5
RS-232	Labeling of an operating element on the product (example: socket of the RS-232 interface)
	Warning signs affixed to the product that refer to detailed information in this manual.

1.3 Other Applicable Documents

The devices and software tools which are mentioned in this documentation are described in their own manuals.

The latest versions of the user manuals are available for download (p. 3) on our website.

Product	Document
E-625.CR controller	PZ166E
E-665.CR controller	PZ127E
E-610.C0 piezo controller OEM board	PZ72E
E-609 OEM piezo controller	E609T0001
E-709.CRG digital single-channel piezo controller	PZ222E
E-753 digital piezo controller	PZ193E
E-500 modular piezo controller	PZ62E

Product	Document
E-509.C3A control module for capacitive sensors	PZ77E
E-503 3-channel amplifier	PZ62E
E-505 single-channel high-performance amplifier	PZ62E
E-517 interface and display module	PZ214E
E-712 digital piezo controller	PZ195E
E-725 digital piezo controller	PZ197E
E-761 digital piezo controller	PZ164E
P-5xx / P-6xx / P-7xx piezo positioning systems	PZ240EK Short Instructions

1.4 Downloading Manuals

INFORMATION

If a manual is missing on our website or if there are problems in downloading:

- Contact our customer service department (p. 37).

The current versions of the manuals are found on our website. Access to the manuals of Hexapod systems and electronics whose scope of delivery includes a CD is password-protected. The password is stored on the CD.

Download freely accessible manuals

1. Open the website <http://www.pi-portal.ws>.
2. Click **Downloads**.
3. Click the corresponding category (e. g. **P Piezo Actuators, Nanopositioning & Scanning Systems**).
4. Click the corresponding product code (e. g. **P-517**).
5. Click **Documents**.

The available manuals are displayed.

6. Click the desired manual and save it on the hard disk of your PC or on a data storage medium.

Download password-protected manuals

1. Carry out steps 1 to 5 of the download process for freely accessible manuals.
2. Insert the product CD in the PC drive.
3. Switch to the **Manuals** directory on the CD.
4. In the **Manuals** directory, open the Release News (file including **releasenews** in the file name).
5. Find the user name and password in the **User login for software download** section in the Release News.
6. In the **User login** area on the left margin in the website, enter the user name and the password in the corresponding fields.
7. Click **Login**.
The available manuals are displayed.
8. Click the desired manual and save it on the hard disk of your PC or on a data storage medium.

2 Safety

In this Chapter

Intended Use	5
General Safety Instructions	6
Organizational Measures.....	7

2.1 Intended Use

The P-5x7/P-5x8 is a laboratory device as defined by DIN EN 61010-1. It is intended to be used in interior spaces and in an environment which is free of dirt, oil, and lubricants.

Based on its design and realization, the P-5x7/P-5x8 is intended for fine positioning as well as the fast and precise motion of small objects. The specifications of the P-5x7/P-5x8 apply to horizontal mounting. The motion is performed as follows depending on the model:

Model	Motion	Axis
.2CD / .2CL	in two axes horizontally	X, Y
.3CD / .3CL	in two axes horizontally and in one axis vertically	X, Y, Z
.ZCD / .ZCL	in one axis vertically	Z
.RCD	in two axes horizontally and in one axis rotationally	X, Y, θZ
.TCD	in one axis vertically and in two axes rotationally	Z, θX , θY

The intended use of the P-5x7/P-5x8 is only possible in combination with suitable drive and control electronics (p. 12) available from PI. The electronics is not included in the scope of delivery of the P-5x7/P-5x8.

The electronics must provide the required operating voltages. To ensure proper performance of the servo-control system, the electronics must be able to read out and process the signals from the capacitive sensors.

2.2 General Safety Instructions

The P-5x7/P-5x8 is built according to state-of-the-art technology and recognized safety standards. Improper use can result in personal injury and/or damage to the P-5x7/P-5x8.

- Only use the P-5x7/P-5x8 for its intended purpose, and only use it if it is in a good working order.
- Read the user manual.
- Immediately eliminate any faults and malfunctions that are likely to affect safety.

The operator is responsible for the correct installation and operation of the P-5x7/P-5x8.

Mechanical forces can damage or misalign the P-5x7/P-5x8.

- Avoid impacts that affect the P-5x7/P-5x8.
- Do **not** drop the P-5x7/P-5x8.
- Do **not** exceed the maximum permissible stress and load capacities according to the specifications (p. 39).
- Only hold the P-5x7/P-5x8 externally by the base body.

The P-5x7/P-5x8 is maintenance-free and achieves its positioning accuracy as a result of the optimum alignment of mechanical components and piezo actuators. Loosened screws cause a loss in positioning accuracy.

- Only loosen screws according to the instructions in this manual.
- Do **not** open the P-5x7/P-5x8.

2.3 Organizational Measures

User manual

- Always keep this user manual available by the P-5x7/P-5x8.
The latest versions of the user manuals are available for download (p. 3) on our website.
- Add all information given by the manufacturer to the user manual, for example supplements or Technical Notes.
- If you pass the P-5x7/P-5x8 on to other users, also turn over this user manual as well as other relevant information provided by the manufacturer.
- Only use the device on the basis of the complete user manual. Missing information due to an incomplete user manual can result in minor injury and property damage.
- Only install and operate the P-5x7/P-5x8 after having read and understood this user manual.

Personnel qualification

The P-5x7/P-5x8 may only be installed, started up, operated, maintained and cleaned by authorized and qualified staff.

3 Product Description

In this Chapter

Model Overview	9
Product View	11
Scope of Delivery	11
Recommended Piezo Controllers.....	12
Technical Features	13

3.1 Model Overview

The following standard versions of the P-5x7/P-5x8 are available:

Model	Description
P-517.2CD	Precision XY nanopositioning system, 100 μm \times 100 μm , capacitive sensors, parallel metrology, Sub-D connector(s)
P-517.2CL	Precision XY nanopositioning system, 100 μm \times 100 μm , capacitive sensors, parallel metrology, LEMO connector(s)
P-527.2CD	Precision XY nanopositioning system, 200 μm \times 200 μm , capacitive sensors, parallel metrology, Sub-D connector(s)
P-527.2CL	Precision XY nanopositioning system, 200 μm \times 200 μm , capacitive sensors, parallel metrology, LEMO connector(s)
P-517.3CD	Precision XYZ nanopositioning system, 100 μm \times 100 μm \times 20 μm , capacitive sensors, parallel metrology, Sub-D connector(s)
P-517.3CL	Precision XYZ nanopositioning system, 100 μm \times 100 μm \times 20 μm , capacitive sensors, parallel metrology, LEMO connector(s)
P-527.3CD	Precision XYZ nanopositioning system, 200 μm \times 200 μm \times 20 μm , capacitive sensors, parallel metrology, Sub-D connector(s)
P-527.3CL	Precision XYZ nanopositioning system, 200 μm \times 200 μm \times 20 μm , capacitive sensors, parallel metrology, LEMO connector(s)

Model	Description
P-517.RCD	Precision XY / rotation nanopositioning system, 100 μm \times 100 μm , 2 mrad, capacitive sensors, parallel metrology, Sub-D connector(s)
P-527.RCD	Precision XY / rotation nanopositioning system, 200 μm \times 200 μm , 4 mrad, capacitive sensors, parallel metrology, Sub-D connector(s)
P-558.ZCD	Precision nanopositioning Z stage, 50 μm , direct metrology, capacitive sensors, Sub-D connector(s)
P-558.ZCL	Precision nanopositioning Z stage, 50 μm , direct metrology, capacitive sensors, LEMO connector(s)
P-518.ZCD	Precision nanopositioning Z stage, 100 μm , direct metrology, capacitive sensors, Sub-D connector(s)
P-518.ZCL	Precision nanopositioning Z stage, 100 μm , direct metrology, capacitive sensors, LEMO connector(s)
P-528.ZCD	Precision nanopositioning Z stage, 200 μm , direct metrology, capacitive sensors, Sub-D connector(s)
P-528.ZCL	Precision nanopositioning Z stage, 200 μm , direct metrology, capacitive sensors, LEMO connector(s)
P-558.TCD	Precision nanopositioning Z/tip/tilt stage, 50 μm , 0.6 mrad, parallel metrology, capacitive sensors, Sub-D connector(s)
P-518.TCD	Precision nanopositioning Z/tip/tilt stage, 100 μm , 1.4 mrad, parallel metrology, capacitive sensors, Sub-D connector(s)
P-528.TCD	Precision nanopositioning Z/tip/tilt stage, 200 μm , 2.4 mrad, parallel metrology, capacitive sensors, Sub-D connector(s)

3.2 Product View

The illustration serves as an example and can differ from your stage model.

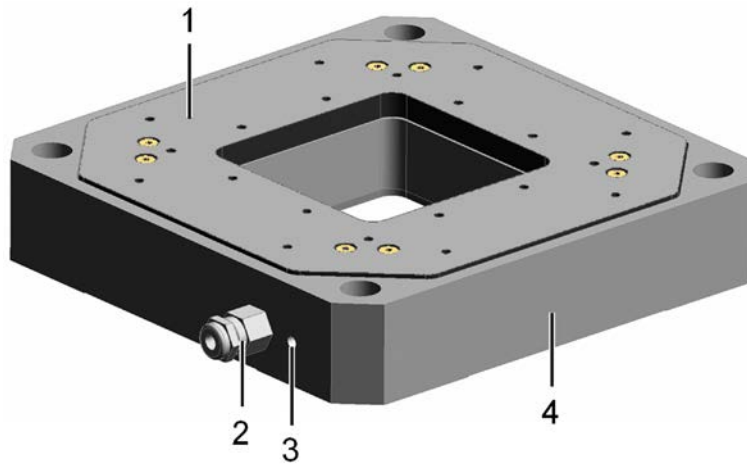


Figure 1: Example of product view

- 1 Moving platform
- 2 Cable exit
- 3 Protective earth connection
- 4 Base body

3.3 Scope of Delivery

Order Number	Items
P-5x7/P-5x8	Stage according to order (p. 9)
-	Transport lock, consisting of: <ul style="list-style-type: none"> ▪ Support frame ▪ 4 plastic screws
000036450	M4 screw set for protective earth, consisting of: <ul style="list-style-type: none"> ▪ 1 M4x8 flat-head screw with cross recess, ISO 7045 ▪ 2 safety washers ▪ 2 flat washers
P500T0002	Technical Note with instructions on unpacking and packing P-5xx stages
PZ240EK	Short instructions for piezo positioning systems

3.4 Recommended Piezo Controllers

To operate a P-5x7/P-5x8, you need a piezo controller. The device is selected depending on the type of application. The table below lists suitable controllers.

Controller	Channels	P-5x7.2CD/ .3CD/.RCD; P-5x8.TCD	P-5x7.2CL	P-5x7.3CL	P-5x8.ZCD	P-5x8.ZCL
E-625.CR / E-665.CR controller, bench-top device with digital interface	1	-	-	-	X	-
E-610.C0 piezo controller OEM board	1	-	-	-	-	X
E-609 OEM piezo controller	1	-	-	-	X	-
E-709.CRG digital single-channel piezo controller	1	-	-	-	X	-
E-753 digital piezo controller (bench-top device)	1	-	-	-	X	-
E-500 modular piezo controller with E-509.C1A control module for capacitive sensors and E-505 1-channel amplifier Optional: E-517 interface and display module	1	-	-	-	-	X
E-500 modular piezo controller with E-509.C3A control module for capacitive sensors and E-503 3-channel amplifier Optional: E-517 interface and display module	3	-	-	X	-	-
E-500 modular piezo controller with E-509.C3A control module for capacitive sensors and 3 × E-505 1-channel high-performance amplifier Optional: E-517 interface and display module	3	-	-	X	-	-

Controller	Channels	P-5x7.2CD/ .3CD/.RCD; P-5x8.TCD	P-5x7.2CL	P-5x7.3CL	P-5x8.ZCD	P-5x8.ZCL
E-500 modular piezo controller with E-509.C2A control module for capacitive sensors and 2 x E-505 1-channel high-performance amplifier Optional: E-517 interface and display module	2	-	X	-	-	-
E-712 digital piezo controller, modular system for up to 6 axes	3 / 6	X	-	-	-	-
E-725 digital piezo controller for up to 3 axes	3	X	-	-	-	-
E-761 digital piezo controller for up to 3 axes, PCI card	3	X	-	-	-	-

3.5 Technical Features

3.5.1 PICMA® Piezo Actuators

P-5x7/P-5x8 stages are driven by PICMA® piezo actuators. PICMA® actuators have all-ceramic insulation and are therefore far superior to conventional actuators in respect to performance and lifetime. The monolithic piezoceramic block is protected against humidity and failure due to increased leakage current by a ceramic insulation layer. In this way, an especially high reliability is achieved even under extreme ambient conditions. In contrast to motorized drives, there are no rotating parts or friction. The piezo actuators are therefore backlash-, maintenance- and wear-free.

3.5.2 Flexure Guides

P-5x7/P-5x8 stages have flexure guides (flexures) for frictionless motion and high guiding accuracies.

A flexure guide is an element which is free from static and sliding friction. It is based on the elastic deformation (bending) of a solid (e.g. steel) and does not have any rolling or sliding parts. Flexure elements have a high stiffness and load capacity. Flexure guides are maintenance- and wear-free. They are 100% vacuum compatible, function in a wide temperature range and do not require any lubricants.

3.5.3 Capacitive Sensors

Capacitive sensors measure the position directly on the moving platform (direct metrology) and work without contact. Neither friction nor hysteresis interferes with the motion, which allows excellent linearity values to be achieved in combination with the high position resolution. In connection with suitable electronics, capacitive sensors achieve the best resolution, stability and bandwidth.

3.5.4 ID Chip (Only Models With Sub-D Connector)

An ID chip is located in the Sub-D connector of the stage. When the stage is calibrated at the factory with digital electronics, the calibration data is saved together with specific product information on the ID chip. When switched on, digital electronics read the data from the ID chip of the connected stage. Stages whose ID chip contains the calibration data can therefore be connected to any suitable digital electronics without a new calibration.

For more information on the ID chip, see the manual of the controller used.

4 Unpacking

NOTICE



Mechanical overload from incorrect handling!

An impermissible mechanical overload of the moving platform of the P-5x7/P-5x8 can cause damage to the piezo actuators, sensors and flexure joints of the P-5x7/P-5x8 as well as losses of accuracy.

- Only ship the P-5x7/P-5x8 in the original packaging.
- Only hold the P-5x7/P-5x8 externally by the base body.

The P-5x7/P-5x8 is delivered with installed transport lock. The following figures serve as examples and can differ from your stage model.

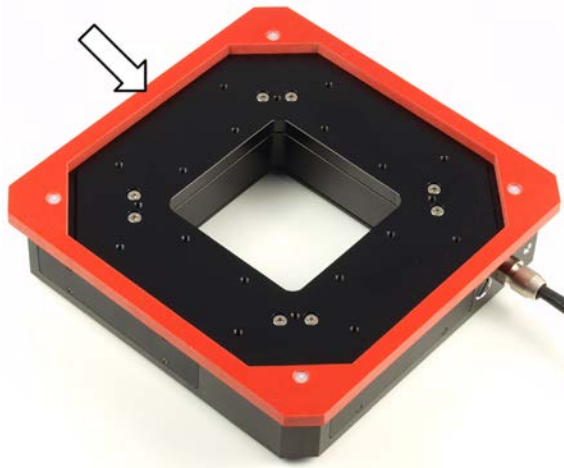


Figure 2: Exemplary view: Stage with transport lock (support frame marked with arrow) for protecting the moving platform

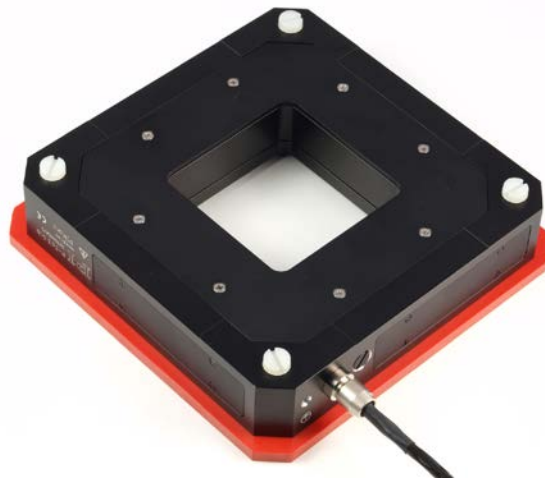
Tools and accessories

- Suitable screwdriver

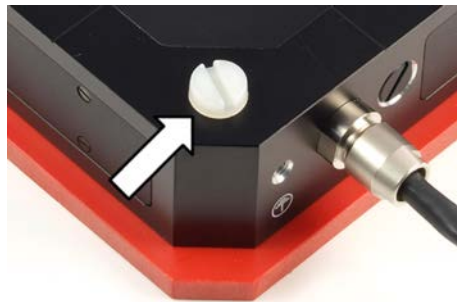
Unpacking the P-5x7/P-5x8

1. Unpack the P-5x7/P-5x8 with care.
2. Compare the contents against the items covered by the contract and against the packing list. If parts are incorrectly supplied or missing, contact PI immediately.

3. Inspect the contents for signs of damage. If you notice signs of damage, contact PI immediately.
4. Remove the transport lock:
 - a) Place the P-5x7/P-5x8 on a surface with the support frame facing downwards.



- b) Release the four plastic screws with a screwdriver. In the following figure, one of the screws is marked with an arrow.



- c) Remove the plastic screws and the support frame.
5. Keep all packaging materials and the transport lock in case the product needs to be transported again later.

5 Installation

In this Chapter

General Notes on Installation	17
Connecting the P-5x7/P-5x8 to the Protective Earth Conductor	19
Mounting the P-5x7/P-5x8	21
Affixing the Load.....	23

5.1 General Notes on Installation

CAUTION



Dangerous voltage and residual charge on piezo actuators!

The P-5x7/P-5x8 is driven by piezo actuators. Temperature changes and compressive stresses can induce charges in piezo actuators. After being disconnected from the electronics, piezo actuators can also stay charged for several hours. Touching or short-circuiting the contacts in the connector of the P-5x7/P-5x8 can lead to minor injuries. In addition, the piezo actuators can be destroyed by an abrupt contraction.

- Do **not** open the P-5x7/P-5x8.
- Discharge the piezo actuators of the stage before installation:
Connect the stage to the switched-off PI controller, which is equipped with an internal discharge resistor.
- Do **not** pull out the connector from the electronics during operation.



For stages with Sub-D connector:

Touching the contacts in the connector can lead to an electric shock (max. 130 V DC) and minor injuries.

- Do **not** touch the contacts in the connector.
- Secure the connector of the stage with screws against being pulled out of the controller.

NOTICE**Mechanical overload from incorrect handling!**

An impermissible mechanical overload of the moving platform of the P-5x7/P-5x8 can cause damage to the piezo actuators, sensors and flexure joints of the P-5x7/P-5x8 as well as losses of accuracy.

- Only hold the P-5x7/P-5x8 externally by the base body.

NOTICE**Damage from unsuitable cables!**

Unsuitable cables can damage the stage and the electronics.

- Only use cables provided by PI for connecting the P-5x7/P-5x8 to the electronics.

NOTICE**Damage from incorrect mounting!**

Incorrect mounting of the P-5x7/P-5x8 or incorrectly mounted parts can damage the P-5x7/P-5x8.

- Only mount the P-5x7/P-5x8 and the loads on the mounting fixtures (holes) intended for this purpose.

NOTICE**Damage due to incorrectly tightened screws**

Incorrectly tightened screws can cause damage.

- Observe the torque range (p. 46) given for the screws used during installation.

INFORMATION

Extended cables can affect the performance of the P-5x7/P-5x8.

- Do **not** use cable extensions. If you need longer cables, contact our customer service department (p. 37).

5.2 Connecting the P-5x7/P-5x8 to the Protective Earth Conductor


INFORMATION

In the case of P-5x7/P-5x8 stages with Sub-D connectors, ground loops can occur when the stage is grounded via its protective earth connector as well as by the shield of the connection cable for the electronics.

- If a ground loop occurs, contact our customer service department (p. 37).

INFORMATION

- Observe the applicable standards for mounting the protective earth conductor.

The P-5x7/P-5x8 is equipped with an M4 hole for fastening the protective earth conductor. This hole is located next to the cable exit and is marked with the protective earth conductor symbol  (see "Dimensions", p. 44).

Prerequisite

- ✓ You have read and understood the General Notes on Installation (p. 17).
- ✓ The stage is **not** connected to the electronics.

Tools and accessories

- Suitable protective earth conductor: Cross-sectional area of the cable $\geq 0.75 \text{ mm}^2$
- Supplied M4 protective earth screw set (p. 11) for connecting the protective earth conductor
- Suitable screwdriver

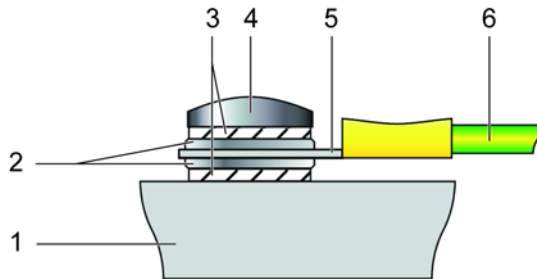


Figure 3: Mounting of the protective earth conductor (profile view)

- 1 Base body of the P-5x7/P-5x8
- 2 Flat washer
- 3 Safety washer
- 4 Screw
- 5 Cable lug
- 6 Protective earth conductor

Connecting the P-5x7/P-5x8 to the protective earth conductor

1. If necessary, fasten a suitable cable lug to the protective earth conductor.
2. Fasten the cable lug of the protective earth conductor using the M4 screw on the protective earth connection of the P-5x7/P-5x8 as shown in the profile view.
3. Tighten the M4 screw with a torque of 1.2 Nm to 1.5 Nm.
4. Make sure that the contact resistance at all connection points relevant for mounting the protective earth conductor is $<0.1 \Omega$ at 25 A.

5.3 Mounting the P-5x7/P-5x8

NOTICE



Warping of the P-5x7/P-5x8 due to mounting on uneven surfaces!

Mounting the P-5x7/P-5x8 on an uneven surface can warp the P-5x7/P-5x8. Warping reduces the accuracy.

- Mount the P-5x7/P-5x8 on an even surface. The recommended evenness of the surface is $\leq 20 \mu\text{m}$.
- For applications with great temperature changes:
Only mount the P-5x7/P-5x8 on surfaces that have the same or similar thermal expansion properties as the P-5x7/P-5x8.

NOTICE



Tensile stress on piezo actuator with vertical mounting!

When the stage is mounted vertically, tensile stress can result in particular alignments that reduces the preload of the piezo actuator and thus destroys it.

- If you want to mount the P-5x7/P-5x8 vertically, contact our customer service department (p. 37).

NOTICE



Protruding screw heads!

Protruding screw heads can damage the P-5x7/P-5x8.

- Ensure that the screw heads do not protrude from counter-sunk holes so that they do not interfere with the stage motion.

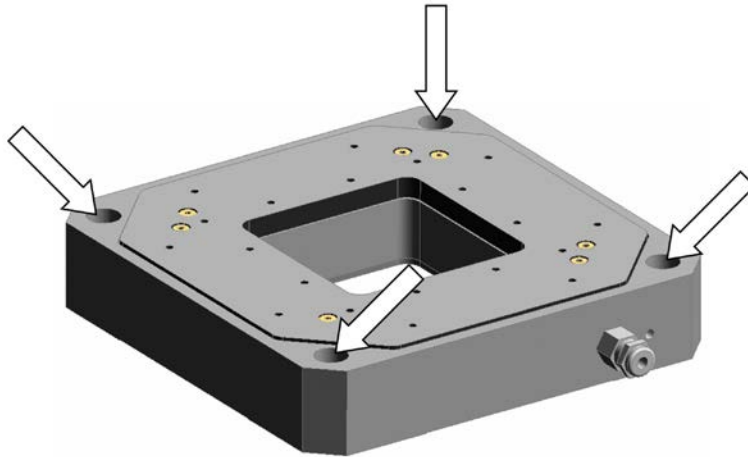


Figure 4: Mounting holes in the base body

Prerequisite

- ✓ You have read and understood the General Notes on Installation (p. 17).

Tools and accessories

- Screws of appropriate size and length (p. 44)
- Suitable tools

Mounting the stage on a surface

1. Position the stage on an even surface.
2. Fasten the stage to the mounting holes (see figure) with suitable screws. Observe the specified torque range (p. 46) while doing so.

5.4 Affixing the Load

NOTICE



Mechanical overload due to high torques and high loads!

When affixing the load, high torques and high loads can overload the moving platform of the P-5x7/P-5x8. Mechanical overload can cause damage to the piezo actuators, sensors and flexure joints of the P-5x7/P-5x8 and lead to losses in accuracy.

- When affixing the load, make sure that the sum of all torques that act on the moving platform does **not** exceed the maximum torque (p. 46) of the used screws.
- Do **not** exceed the maximum permissible stress and load capacities according to the specifications (p. 39).

NOTICE



Warping of the P-5x7/P-5x8 due to affixing of loads with uneven contact surface!

Affixing loads with an uneven contact surface can warp the P-5x7/P-5x8. Warping reduces the accuracy.

- Only affix loads on the P-5x7/P-5x8 whose contact surface with the moving platform of the stage has an evenness of at least 20 µm.
- For applications with great temperature changes:
Only affix loads on the P-5x7/P-5x8 that have the same or similar thermal expansion properties as the P-5x7/P-5x8.

NOTICE



Center of load at unsuitable position!

If the center of load is located far outside of the moving platform (e. g. high set-ups and long levers), the P-5x7/P-5x8 can be damaged from high strain on the flexure guides, high torques and oscillations.

- If the center of the load to be affixed is far above or to the side of the moving platform, adjust the controller settings before start-up or contact our customer service department (p. 37).

NOTICE**Screws that are too long!**

The P-5x7/P-5x8 can be damaged by screws that are too long.

- Note the depth of the mounting holes in the moving platform (p. 44).
- Only use screws of the correct length for the respective mounting holes.

INFORMATION

The arrows in the figures (see "Dimensions", p. 44) show the positive direction of motion.

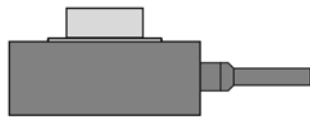
Center of load at the optimum position:

Figure 5: Example of an optimally affixed load

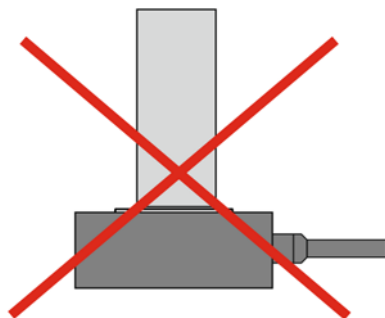
Center of load at an unsuitable position:

Figure 6: High set-up and center of load far above the moving platform

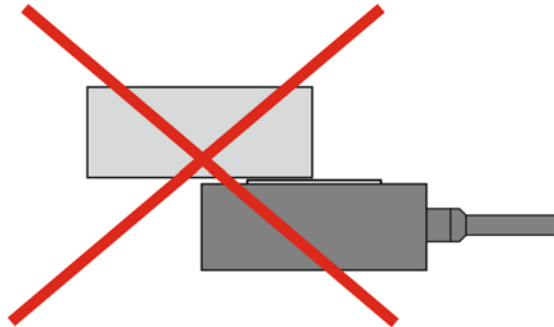


Figure 7: Long lever and center of load on the side of the moving platform

Prerequisite

- ✓ You have read and understood the General Notes on Installation (p. 17).

Tools and accessories

- Screws of appropriate size and length (p. 44)
- Suitable tools

Affixing the Load

- Only affix loads to the threaded holes (p. 44) intended for this purpose and with suitable screws. Observe the specified torque range (p. 46) while doing so.
- Affix the load so that it is centered and that the center of load is on the moving platform.

6 Start-Up and Operation

In this Chapter

General Notes on Start-Up and Operation	27
Operating the P-5x7/P-5x8	29
Discharging the P-5x7/P-5x8	30

6.1 General Notes on Start-Up and Operation

CAUTION



Risk of electric shock if the protective earth conductor is not connected!

If a protective earth conductor is not or not properly connected, dangerous touch voltages can occur on the P-5x7/P-5x8 in the case of malfunction or failure of the system. If touch voltages exist, touching the P-5x7/P-5x8 can result in minor injuries from electric shock.

- Connect the P-5x7/P-5x8 to a protective earth conductor (p. 19) before start-up.
- Do **not** remove the protective earth conductor during operation.
- If the protective earth conductor has to be removed temporarily (e. g. in the case of modifications), reconnect the P-5x7/P-5x8 to the protective earth conductor before starting it up again.

NOTICE



Destruction of the piezo actuator by electric flashovers!

The use of the P-5x7/P-5x8 in environments that increase the electrical conductivity can lead to the destruction of the piezo actuator by electric flashovers. Electric flashovers can be caused by moisture, high humidity, liquids and conductive materials such as metal dust. In addition, electric flashovers can also occur in certain air pressure ranges due to the increased conductivity of the air.

- Avoid operating the P-5x7/P-5x8 in environments that can increase the electric conductivity.
- Only operate the P-5x7/P-5x8 within the permissible ambient conditions and classifications (p. 43).

NOTICE**Reduced lifetime of the piezo actuator due to permanently high voltage!**

The permanent application of a high static voltage to piezo actuators leads to a considerable reduction in the lifetime of the piezo ceramics of the actuator.

- When the P-5x7/P-5x8 is not used but the controller remains switched on to ensure temperature stability, discharge the P-5x7/P-5x8 (p. 30).

NOTICE**Operating voltages that are too high or incorrectly connected!**

Operating voltages that are too high or incorrectly connected can cause damage to the P-5x7/P-5x8.

- Only operate the P-5x7/P-5x8 with controllers/drivers and original accessories from PI.
- Do **not** exceed the operating voltage range (p. 42) for which the P-5x7/P-5x8 is specified.
- Only operate the P-5x7/P-5x8 when the operating voltage is properly connected; see "Pin Assignment" (p. 47).

NOTICE**Uncontrolled oscillation!**

Oscillations can cause irreparable damage to the stage. Oscillations are indicated by a humming and can result from the following causes:

- A change in the load and/or dynamics requires the servo-control parameters to be adjusted.
- The stage is operated near its resonant frequency.

If you notice oscillations:

- In closed-loop operation, immediately switch off the servo mode.
- In open-loop operation, immediately stop the stage.

INFORMATION

The arrows in the figures (see "Dimensions", p. 44) show the positive direction of motion.

INFORMATION

Systems are calibrated at the factory to achieve optimum performance. Replacing the system components will cause a loss in performance when stages are used, whose ID chip (p. 14) does not contain any calibration data, or when analog controllers are used.

- Note the assignment of the stage axes to the controller channels, which is given by the calibration label of the piezo servo controller.
- If the piezo servo controller or the stage has to be replaced, recalibrate the axis displacement (see controller manual) or contact our customer service department (p. 37).

INFORMATION

Systems are calibrated at the factory at a temperature between 21°C and 24°C. When operated outside of this temperature range, the travel range of the stage can decrease.

If you are operating the stage outside of the given temperature range and the travel range is reduced:

- Perform a recalibration of the axis displacement (see controller manual) or contact our customer service department (p. 37).

INFORMATION

Sound and vibration (e.g. footfall, impacts) can be transmitted to the stage and can affect its performance with regard to position stability.

- Avoid transmitting sound and vibration while the stage is being operated.

6.2 Operating the P-5x7/P-5x8

- Follow the instructions in the manual of the used controller for start-up and operation of the P-5x7/P-5x8.

6.3 Discharging the P-5x7/P-5x8

The P-5x7/P-5x8 must be discharged in the following cases:

- Before installation
- If the P-5x7/P-5x8 is not used but the controller remains switched on to ensure temperature stability
- Before demounting (e.g. before cleaning and transporting the P-5x7/P-5x8 and for modifications)

The P-5x7/P-5x8 is discharged through the internal discharge resistor of the controller from PI.

Discharging a P-5x7/P-5x8 that is connected to the controller

In closed-loop operation:

1. Switch off the servo mode on the controller.
2. Set the piezo voltage to 0 V on the controller.

In open-loop operation:

- Set the piezo voltage to 0 V on the controller.

Discharging a P-5x7/P-5x8 that is not connected to the controller

- Connect the stage to the switched-off controller from PI.

7 Maintenance

In this Chapter

General Notes on Maintenance.....	31
Packing the P-5x7/P-5x8 for Transport	31
Cleaning the P-5x7/P-5x8.....	33

7.1 General Notes on Maintenance

NOTICE



Misalignment from loosening screws!

The P-5x7/P-5x8 is maintenance-free and achieves its positioning accuracy as a result of the optimum alignment of mechanical components and piezo actuators. Loosened screws cause a loss in positioning accuracy.

- Only loosen screws according to the instructions in this manual.
- Do **not** open the P-5x7/P-5x8.

7.2 Packing the P-5x7/P-5x8 for Transport

NOTICE



Mechanical overload from incorrect handling!

An impermissible mechanical overload of the moving platform of the P-5x7/P-5x8 can cause damage to the piezo actuators, sensors and flexure joints of the P-5x7/P-5x8 as well as losses of accuracy.

- Only ship the P-5x7/P-5x8 in the original packaging.
- Only hold the P-5x7/P-5x8 externally by the base body.

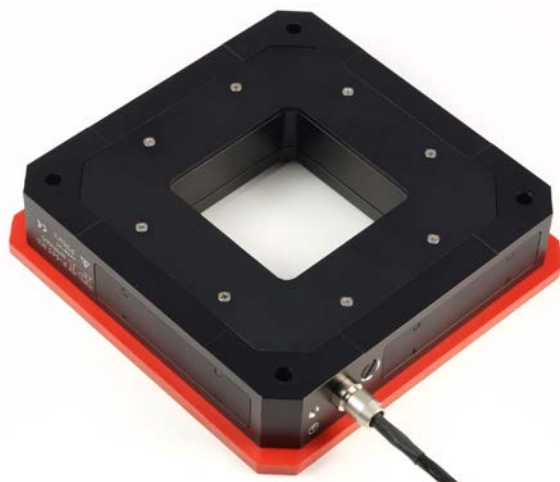
The following figures serve as examples and can differ from your stage model.

Tools and accessories

- Original packaging
- Transport lock, included in delivery, consisting of:
 - Support frame
 - 4 plastic screws
- Suitable screwdriver

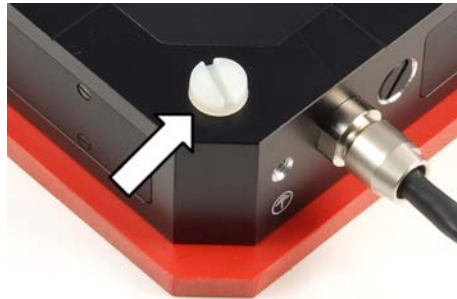
Packing the P-5x7/P-5x8

1. Attach the transport lock:
 - a) Place the support frame on a surface.
 - b) Place the stage with its top side facing downwards on the support frame.



- c) Align the stage so that the mounting holes in the stage are above the mounting holes in the support frame.

- d) Fasten the support frame to the mounting holes of the stage with the four plastic screws. In the following figure, one of the screws is marked with an arrow.



2. Pack the stage in the original packaging.

7.3 Cleaning the P-5x7/P-5x8

Prerequisites

- ✓ You have discharged the piezo actuators of the P-5x7/P-5x8 (p. 30).
- ✓ You have disconnected the P-5x7/P-5x8 from the controller.

Cleaning the P-5x7/P-5x8

- Clean the surfaces of the P-5x7/P-5x8 with a cloth slightly dampened with a mild cleanser or disinfectant (e.g. alcohol or isopropanol).
- Do **not** do any ultrasonic cleaning.

8 Troubleshooting

Problem	Possible Causes	Solution
No or limited motion	The cable is not connected correctly	➤ Check the cable connections.
	Excessive load	➤ Do not exceed the maximum permissible stress and load capacities according to the specifications (p. 39).
	Zero shift of the sensor for the following reasons: <ul style="list-style-type: none"> ▪ Load applied in direction of motion ▪ Ambient/operating temperature of the stage far above or below calibration temperature (21°C to 24°C) 	➤ Perform a zero-point adjustment of the sensor (see controller manual).
Reduced accuracy	Warping of the base body or the moving platform	<ul style="list-style-type: none"> ➤ Only mount the P-5x7/P-5x8 on surfaces with the following characteristics: <ul style="list-style-type: none"> – Evenness of at least 20 µm – The thermal expansion properties are similar to those of the P-5x7/P-5x8 (e. g. surfaces made of aluminum). ➤ Only affix loads with the following characteristics on the P-5x7/P-5x8: <ul style="list-style-type: none"> – The contact surface of the load with the moving platform of the stage has an evenness of at least 20 µm. – The thermal expansion properties are similar to those of the P-5x7/P-5x8 (e. g. loads made of aluminum).

Problem	Possible Causes	Solution
	P-5x7/P-5x8 or controller has been replaced	<p>When stages whose ID chip (p. 14) does not contain any calibration data or LEMO connectors are used, the axis displacement has to be recalibrated after the P-5x7/P-5x8 or the controller has been replaced.</p> <ul style="list-style-type: none"> ➤ Perform a recalibration of the axis displacement (see controller manual) or contact our customer service department (p. 37).
	Axes were mixed up during connection (only with LEMO connectors)	<ul style="list-style-type: none"> ➤ Observe the assignment of the axes when connecting the stage to the controller. This assignment is indicated by labels on the devices.
The stage starts oscillating or positions inaccurately	Servo-control parameters incorrectly set because e. g. the load was changed	<ol style="list-style-type: none"> 1. Immediately switch off the servo mode of the corresponding stage axes. 2. Check the settings of the servo-control parameters on the controller. 3. Adjust the servo-control parameters on the controller according to the load change.
	Open-loop operation near the resonant frequency	<ul style="list-style-type: none"> ➤ In open-loop operation, only operate the stage with a frequency that is below the resonant frequency.

If the problem that occurred with your system is not listed in the table above or cannot be solved as described, contact our customer service department (p. 37).

9 Customer Service

For inquiries and orders, contact your PI sales engineer or send us an e-mail (info@pi.ws).

If you have questions concerning your system, have the following information ready:

- Product codes and serial numbers of all products in the system
- Firmware version of the controller (if present)
- Version of the driver or the software (if present)
- Operating system on the PC (if present)

The latest versions of the user manuals are available for download (p. 3) on our website.

10 Technical Data

In this Chapter

Specifications	39
Ambient Conditions and Classifications	43
Dimensions	44
Torque for Stainless Steel Screws (A2-70)	46
Pin Assignment.....	47

10.1 Specifications

10.1.1 Data Table

	P-517.2CL P-517.2CD	P-527.2CL P-527.2CD	P-517.3CL P-517.3CD	P-527.3CL P-527.3CD	P-517.RCD	P-527.RCD	Unit	Tolerance
Active axes	X, Y	X, Y	X, Y, Z	X, Y, Z	X, Y, θ_z	X, Y, θ_z		
Motion and positioning								
Integrated sensor	Capacitive	Capacitive	Capacitive	Capacitive	Capacitive	Capacitive		
Open-loop travel, -20 to 120 V	130 μm	250 μm	X, Y: 130 μm Z: 25 μm	X, Y: 250 μm Z: 25 μm	X, Y: 130 μm θ_z : ± 1.3 mrad	X, Y: 250 μm θ_z : ± 2.5 mrad		min. (+20%/-0%)
Closed-loop travel	100 μm	200 μm	X, Y: 100 μm Z: 20	X, Y: 200 μm Z: 20	X, Y: 100 μm θ_z : ± 1 mrad	X, Y: 200 μm θ_z : ± 2 mrad		
Open-loop resolution	0.3 nm	0.5 nm	X, Y: 0.3 nm Z: 0.1 nm	X, Y: 0.5 nm Z: 0.1 nm	X, Y: 0.3 nm θ_z : 0.1 μrad	X, Y: 0.5 nm θ_z : 0.1 μrad		typ.
Closed-loop resolution	1 nm	2 nm	X, Y: 1 nm Z: 0.1 nm	X, Y: 2 nm Z: 0.1 nm	X, Y: 1 nm θ_z : 0.3 μrad	X, Y: 2 nm θ_z : 0.3 μrad		typ.
Linearity error	0.03	0.03	0.03	0.03	0.03	0.03	%	typ.
Repeatability	± 5 nm	± 10 nm	X, Y: ± 5 nm Z: ± 1 nm	X, Y: ± 10 nm Z: ± 1 nm	X, Y: ± 5 nm θ_z : ± 0.5 μrad	X, Y: ± 10 nm θ_z : ± 1 μrad		typ.
Mechanical properties								
Stiffness	2	1	X, Y: 2 Z: 15	X, Y: 1 Z: 15	2	1	N/ μm	$\pm 20\%$
Unloaded resonant frequency	450	350	X, Y: 450 Z: 1100	X, Y: 350 Z: 1100	X, Y: 450 θ_z : 400	X, Y: 350 θ_z : 300	Hz	$\pm 20\%$
Resonant frequency in X, Y, at 500 g	250	190	250	190	250	190	Hz	$\pm 20\%$
Resonant frequency in X, Y, at 2500 g	140	110	140	110	140	110	Hz	$\pm 20\%$
Push / pull force capacity in motion direction	50 / 30	50 / 30	50 / 30	50 / 30	50 / 30	50 / 30	N	max.

	P-517.2CL P-517.2CD	P-527.2CL P-527.2CD	P-517.3CL P-517.3CD	P-527.3CL P-527.3CD	P-517.RCD	P-527.RCD	Unit	Tolerance
Drive properties								
Piezo ceramic	PICMA® P-885	PICMA® P-885	PICMA® P-885	PICMA® P-885	PICMA® P-885	PICMA® P-885		
Electrical capacitance	9.2	9.2	X, Y: 9 Z: 6	X, Y: 9 Z: 6	9	9	μF	±20%
Dynamic Operating Current Coefficient*	11.5	5.8	X, Y: 11.5 Z: 37	X, Y: 5.5 Z: 37	11.5	5.5	μA / (Hz × μm)	±20%
Miscellaneous								
Operating temperature range	-20 to 80	-20 to 80	-20 to 80	-20 to 80	-20 to 80	-20 to 80	°C	
Material	Aluminum	Aluminum	Aluminum	Aluminum	Aluminum	Aluminum		
Mass	0.14	0.14	0.145	0.145	0.14	0.14	kg	±5%
Sensor / voltage connection	CL version: LEMO CD version: Sub-D Special	CL version: LEMO CD version: Sub-D Special	CL version: LEMO CD version: Sub-D Special	CL version: LEMO CD version: Sub-D Special	Sub-D Special	Sub-D Special		

The resolution of piezo nanopositioning systems is not limited by friction or stiction. Value given is noise-equivalent motion with the E-503 piezo amplifier module or E-710 digital piezo controller.

*Dynamic Operating Current Coefficient (DOCC) of the linear axes in μA per hertz and μm. Electrical capacitance and DOCC of the rotational axes are based on differential X and Y motion, therefore not stated. Example: P-527.2xx: Sinusoidal operation with 30 μm at 10 Hz requires approximately 1.8 mA current.

Ask about custom designs!

	P-558.ZCD P-558.ZCL	P-558.TCD	P-518.ZCD P-518.ZCL	P-518.TCD	P-528.ZCD P-528.ZCL	P-528.TCD	Unit	Tolerance
Active axes	Z	Z, θ _x , θ _y	Z	Z, θ _x , θ _y	Z	Z, θ _x , θ _y		
Motion and positioning								
Integrated sensor	Capacitive	Capacitive	Capacitive	Capacitive	Capacitive	Capacitive		
Open-loop travel in Z at -20 to 120 V	60	60	140	140	240	240	μm	min. (+20%/-0%)
Open-loop tilt angle in θ _x , θ _y at -20 to 120 V	–	±0.3	–	±0.7	–	±1.2	mrad	min. (+20%/-0%)
Closed-loop travel in Z	50	50	100	100	200	200	μm	
Closed-loop tilt angle in θ _x , θ _y	–	±0.25	–	±0.5	–	±1	mrad	
Open-loop resolution in Z	0.2	0.2	0.2	0.4	0.6	0.6	nm	typ.
Open-loop resolution in θ _x , θ _y	–	0.02	–	0.04	–	0.06	μrad	typ.
Closed-loop resolution in Z	0.5	0.5	0.8	0.8	1	1	nm	typ.
Closed-loop resolution in θ _x , θ _y	–	0.05	–	0.05	–	0.1	μrad	typ.
Linearity error in θ _x , θ _y	–	0.03	–	0.03	–	0.03	%	typ.
Repeatability in Z	±5	±5	±5	±5	±10	±10	nm	typ.
Repeatability in θ _x , θ _y	–	±0.03	–	±0.05	–	±0.1	μrad	typ.
Crosstalk θ _z (motion in Z)	<10	<10	<10	<10	<20	<20	μrad	typ.
Crosstalk θ _x , θ _y (motion in Z)	<50	<50	<50	<50	<100	<100	μrad	typ.

	P-558.ZCD P-558.ZCL	P-558.TCD	P-518.ZCD P-518.ZCL	P-518.TCD	P-528.ZCD P-528.ZCL	P-528.TCD	Unit	Tolerance
Mechanical properties								
Stiffness in Z	4	4	2.7	2.7	1.5	1.5	N/μm	±20%
Unloaded resonant frequency in Z	570	570	500	500	350	350	Hz	±20%
Unloaded resonant frequency in θ_x , θ_y	–	610	–	530	–	390	Hz	±20%
Resonant frequency in Z, at 500 g	410	410	350	350	210	210	Hz	±20%
Resonant frequency in θ_x , θ_y , at 500 g	–	430	–	370	–	250	Hz	±20%
Resonant frequency in Z, at 2500 g	245	245	200	200	130	130	Hz	±20%
Resonant frequency in θ_x , θ_y , at 2500 g	–	240	–	190	–	115	Hz	±20%
Push / pull force capacity	100 / 50	100 / 50	100 / 50	100 / 50	100 / 50	100 / 50	N	max.
Drive properties								
Piezo ceramic	PICMA® P-885	PICMA® P-885	PICMA® P-885	PICMA® P-885	PICMA® P-885	PICMA® P-885		
Electrical capacitance	6	6	8.4	8.4	14.8	14.8	μF	±20%
Dynamic Operating Current Coefficient*	15	15	10.5	10.5	9.2	9.2	μA / (Hz × μm)	±20%
Miscellaneous								
Operating temperature range	-20 to 80	-20 to 80	-20 to 80	-20 to 80	-20 to 80	-20 to 80	°C	
Material	Aluminum	Aluminum	Aluminum	Aluminum	Aluminum	Aluminum		
Dimensions	150 mm × 150 mm × 30 mm	150 mm × 150 mm × 30 mm	150 mm × 150 mm × 30 mm	150 mm × 150 mm × 30 mm	150 mm × 150 mm × 30 mm	150 mm × 150 mm × 30 mm		
Mass	1380	1380	1400	1400	1420	1420	g	±5%
Cable length	1.5	1.5	1.5	1.5	1.5	1.5	m	±10 mm
Sensor / voltage connection	CL version: LEMO CD version: Sub-D Special	Sub-D Special	CL version: LEMO CD version: Sub-D Special	Sub-D Special	CL version: LEMO CD version: Sub-D Special	Sub-D Special		




The resolution of piezo nanopositioning systems is not limited by friction or stiction. Value given is noise-equivalent motion with the E-503 piezo amplifier module or E-710 digital piezo controller.

*Dynamic Operating Current Coefficient (DOCC) of the linear axes in μA per hertz and μm. Electrical capacitance and DOCC of the rotational axes are based on differential X and Y motion, therefore not stated. Example: P-558.ZCL: Sinusoidal operation with 10 μm at 10 Hz requires approximately 1.7 mA current.

Ask about custom designs!

10.1.2 Maximum Ratings

P-5x7/P-5x8 stages are designed for the following operating parameters:

Stage	Maximum Operating Voltage 	Maximum Operating Frequency (Unloaded) 	Maximum Power Consumption 
P-517.2CD P-517.2CL P-517.RCD	-20 to +120 V	150 Hz (in X and Y)	27 W (in X and Y)
P-527.2CD P-527.2CL P-527.RCD	-20 to +120 V	117 Hz (in X and Y)	21 W (in X and Y)
P-517.3CD P-517.3CL	-20 to +120 V	150 Hz (in X and Y) 367 Hz (in Z)	27 W (in X and Y) 43 W (in Z)
P-527.3CD P-527.3CL	-20 to +120 V	117 Hz (in X and Y) 367 Hz (in Z)	21 W (in X and Y) 43 W (in Z)
P-558.ZCD P-558.ZCL P-558.TCD	-20 to +120 V	190 Hz	22 W
P-518.ZCD P-518.ZCL P-518.TCD	-20 to +120 V	167 Hz	28 W
P-528.ZCD P-528.ZCL P-528.TCD	-20 to +120 V	117 Hz	34 W

10.2 Ambient Conditions and Classifications

The following ambient conditions and classifications must be observed for the P-5x7/P-5x8:

Area of application	For indoor use only
Maximum altitude	2000 m
Air pressure	1100 hPa to 0.1 hPa (corresponds to roughly 825 Torr to 0.075 Torr)
Relative humidity	Highest relative humidity 80% for temperatures up to 31°C Decreasing linearly to 50% relative humidity at 40°C
Operating temperature	-20°C to 80°C
Storage temperature	-20°C to 80°C
Transport temperature	-25°C to 85°C
Overvoltage category	II
Protection class	I
Degree of pollution	1
Degree of protection according to IEC 60529	IP20

10.3 Dimensions

Dimensions in mm. Note that the decimal places are separated by a comma in the drawings.

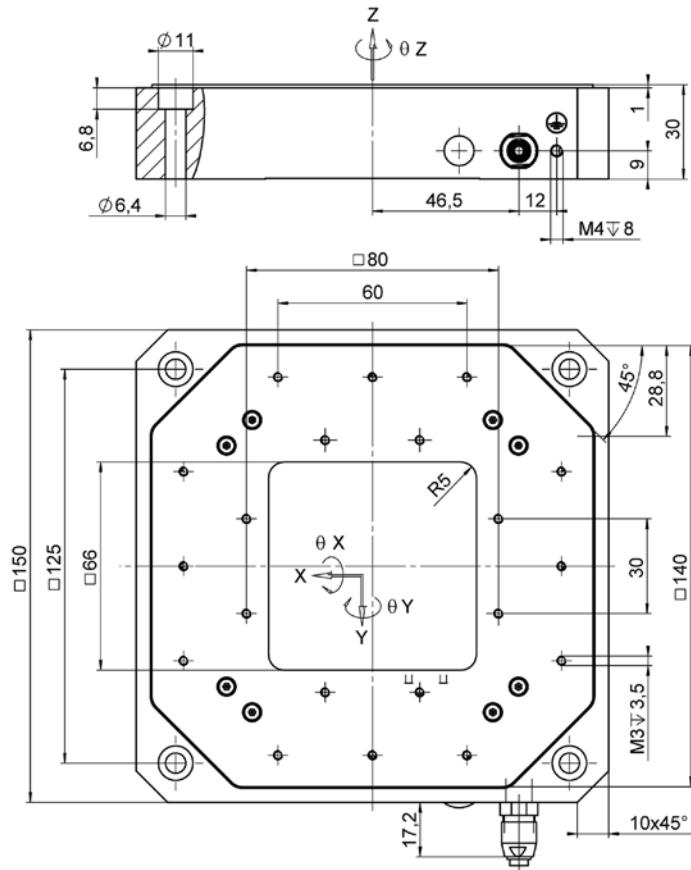


Figure 8: P-5x7

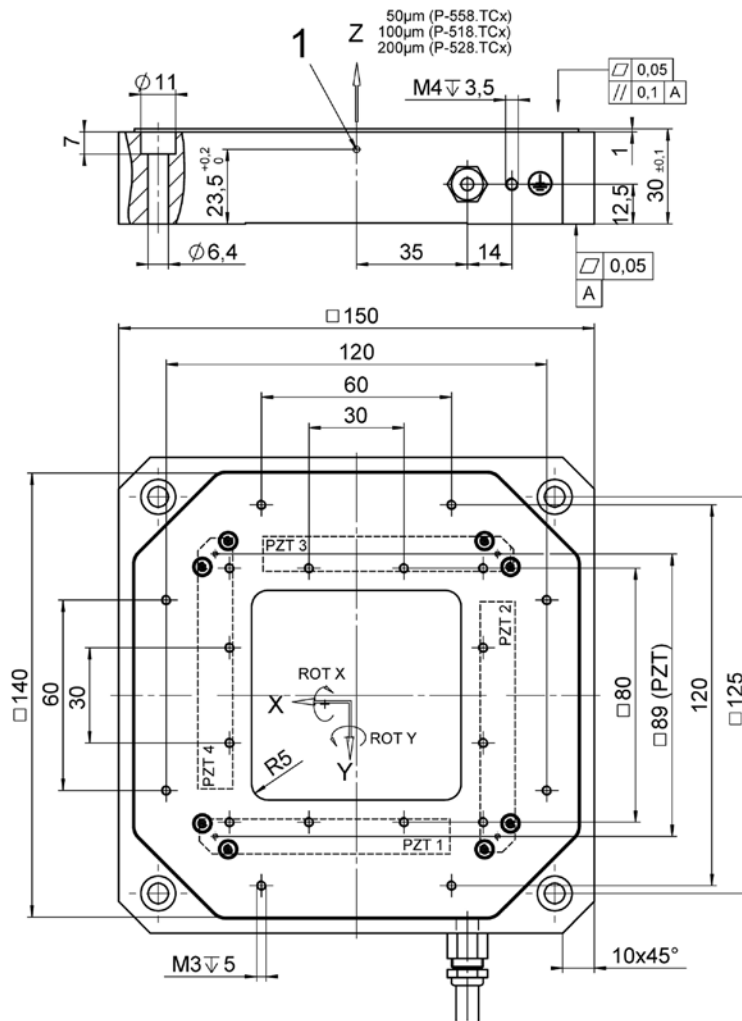


Figure 9: P-5x8.TCx

1: Pivot point, depending on Z

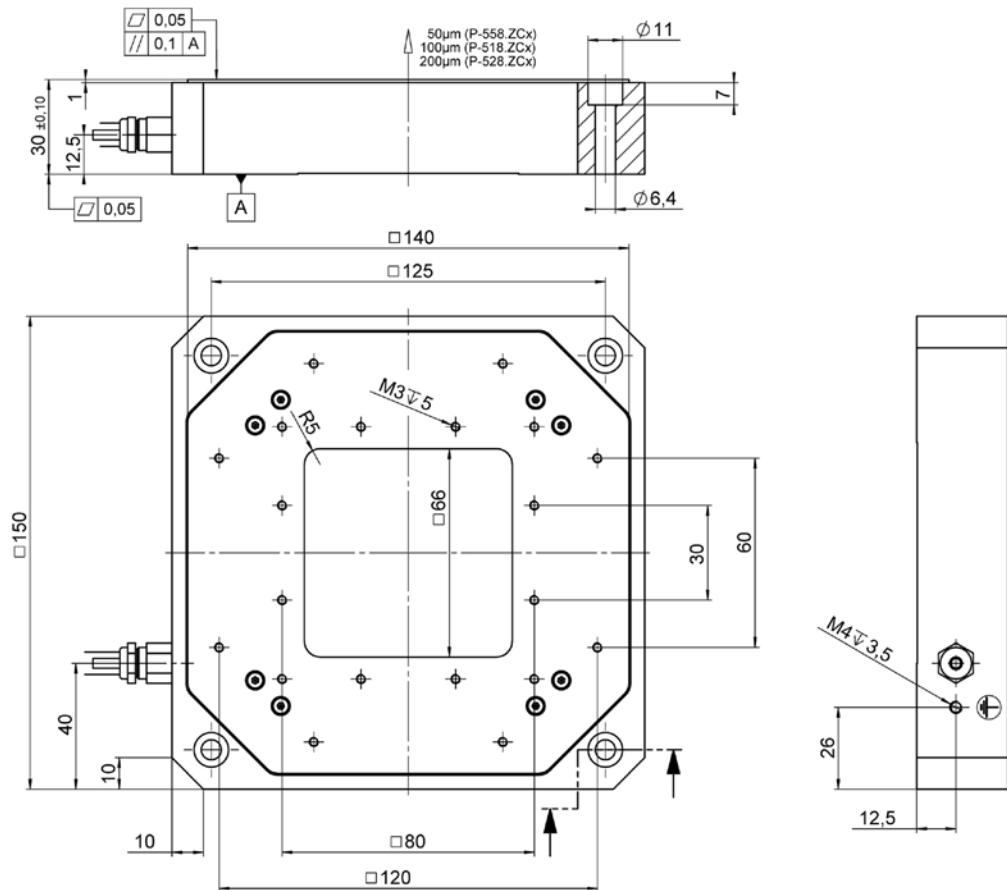


Figure 10: P-5x8.ZCx

10.4 Torque for Stainless Steel Screws (A2-70)

Screw Size	Minimum Torque	Maximum Torque
M6	4 Nm	6 Nm
M5	2.5 Nm	3.5 Nm
M4	1.5 Nm	2.5 Nm
M3	0.8 Nm	1.1 Nm
M2.5	0.3 Nm	0.4 Nm
M2	0.15 Nm	0.2 Nm
M1.6	0.06 Nm	0.12 Nm

10.5 Pin Assignment

Sub-D Mix connector 7W2

Only for P-5x8.ZCD:

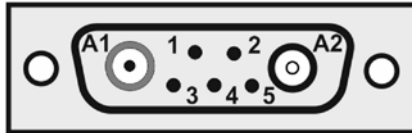


Figure 11: Sub-D Mix connector 7W2: Front side with connections

Pin	Signal	Function
A1 inner conductor	Input	Piezo voltage +
A2 inner conductor	Output	Probe sensor signal (nonmoving part of the capacitive sensor)
A2 outer conductor	GND	Shield
1	Bidirectional	Data line for ID chip
2	GND	<ul style="list-style-type: none"> ▪ Shield of Target ▪ Ground of ID chip when switched on
3	Input	Piezo voltage –
4	Free	–
5	Input	Target sensor signal (movable part of the capacitive sensor)

Sub-D Mix connector 25W3

Only for P-5x7.2CD/.3CD/.RCD and P-5x8.TCD:

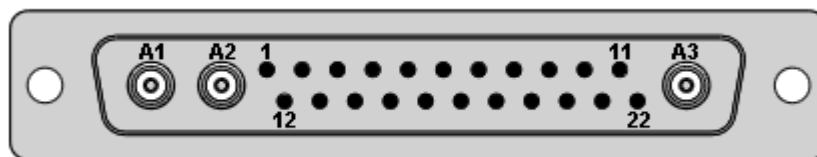


Figure 12: Sub-D Mix connector 25W3: Front side with connections

Pin	Signal	Function
A1 inner conductor	Output	Probe sensor signal, channel 2 (nonmoving part of the capacitive sensor)
A1 outer conductor	GND	Shield of Probe sensor signal, channel 2
A2 inner conductor	Output	Probe sensor signal, channel 3 (nonmoving part of the capacitive sensor)
A2 outer conductor	GND	Shield of Probe sensor signal, channel 3
A3 inner conductor	Output	Probe sensor signal, channel 1 (nonmoving part of the capacitive sensor)
A3 outer conductor	GND	Shield of Probe sensor signal, channel 1
1	Input	Target sensor signal, channel 2 (movable part of the capacitive sensor)
2	Input	Target sensor signal, channel 3 (movable part of the capacitive sensor)
3	GND	Ground of ID chip
4	Bidirectional	Data line for ID chip
5	Free	–
6	Free	–
7	Input	Piezo voltage +, channel 4
8	Input	Piezo voltage +, channel 3
9	Input	Piezo voltage +, channel 2
10	Input	Piezo voltage +, channel 1
11	Input	Target sensor signal, channel 1 (movable part of the capacitive sensor)
12	GND	Shield of Target sensor signal, channel 2
13	GND	Shield of Target sensor signal, channel 3
14	Free	–
15	Free	–
16	Free	–
17	Free	–
18	Input	Piezo voltage –, channel 4
19	Input	Piezo voltage –, channel 3
20	Input	Piezo voltage –, channel 2
21	Input	Piezo voltage –, channel 1
22	GND	Shield of Target sensor signal, channel 1

Stage-dependent assignment of the Sub-D Mix connector 25W3 (X = used):

Stage	Piezo Voltage				Sensor Signal (Probe / Target / Shield)		
	Channel 1 Pins 10 and 21	Channel 2 Pins 9 and 20	Channel 3 Pins 8 and 19	Channel 4 Pins 7 and 18	Channel 1 Pins A3, 11 and 22	Channel 2 Pins A1, 1 and 12	Channel 3 Pins A2, 2 and 13
P-5x7.2CD	X	X	–	–	X	X	–
P-5x7.3CD P-5x7.RCD P-5x8.TCD	X	X	X	–	X	X	X

LEMO coaxial connector

Only for P-5x7.2CL/.3CL and P-5x8.ZCL (one PZT, P and T connector each per axis):

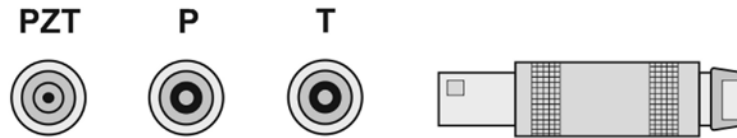


Figure 13: LEMO connectors: PZT, P and T

Connector	Signal	Function	Connector Shell
P	Output	Probe sensor signal (nonmoving part of the capacitive sensor)	Cable shield
T	Input	Target sensor signal (movable part of the capacitive sensor)	Cable shield
PZT	Input	Piezo voltage	Ground

11 Old Equipment Disposal

In accordance with the applicable EU law, electrical and electronic equipment may not be disposed of with unsorted municipal wastes in the member states of the EU.

When disposing of your old equipment, observe the international, national and local rules and regulations.

To meet the manufacturer's product responsibility with regard to this product, Physik Instrumente (PI) GmbH & Co. KG ensures environmentally correct disposal of old PI equipment that was first put into circulation after 13 August 2005, free of charge.

If you have old PI equipment, you can send it postage-free to the following address:

Physik Instrumente (PI) GmbH & Co. KG
Auf der Römerstr. 1
D-76228 Karlsruhe, Germany



12 EC Declaration of Conformity

For the P-5x7/P-5x8, an EC Declaration of Conformity has been issued in accordance with the following European directives:

2006/95/EC, Low Voltage Directive

2004/108/EC, EMC Directive

2011/65/EU, RoHS Directive

The applied standards certifying the conformity are listed below.

Electromagnetic Emission: EN 61000-6-3:2007, EN 55011:2009

Electromagnetic Immunity: EN 61000-6-1:2007

Safety (Low Voltage Directive): EN 61010-1:2010

